

MODEL

**M708**  
SOLAR LED MARINE LANTERN

Using next-generation LEDs, the coast guard-approved M708 solar LED marine lantern offers unparalleled optical efficiency, light uniformity and light output in a compact form factor.

- **Unprecedented reliability:** microprocessor Energy Management system (EMS) monitors and adapts the brightness to environmental conditions for consistent operation and long life under the toughest conditions.
- **Self-contained and low maintenance:** all components incorporated within a compact, stand-alone unit. Replaceable battery pack extends service life, reducing total cost of ownership and delivering significant cost savings. Easy installation / deployment, with no scheduled maintenance for up to five years.
- **Fully configurable and user-programmable:** three range settings (low, medium, high) and 250+ flash patterns using optional infrared programmer.
- **GPS capability for synchronized operation:** optional GPS module enables two or more lanterns to flash in sync.
- **Meets tough industry standards:**
  - o MIL-STD 202G for shock and vibration
  - o MIL-STD 810F for Explosive Atmosphere
  - o NEMA 6P/IP 68 immersion rating
  - o USCG PATON 33CFR66, and PATON 33CFR67 for Class B and C waters
  - o CE
  - o RoHS / WEEE-compliant

- Up to 6 nautical miles of visibility
- Peak intensity up to 268 candela
- Available in all IALA Optimum colours
- Replaceable / recyclable battery pack
- 250+ flash patterns



#### Carmanah / Sabik Marine Customers

- Brazilian Naval Commission
- Canadian Coast Guard
- Maritime and Port Authority of Singapore
- Sydney Harbour, Australia
- Trinity House, UK
- US Coast Guard

#### Applications Include:

- Fixed or floating visual aids to navigation
- Port and marina entrances
- Channel and canal marking
- Offshore oil & gas infrastructure
- Offshore wind/wave power infrastructure
- Research buoys

#### REPRESENTED BY:



**First Choice Marine Supply - 120 N. 20th St. - Tampa, FL 33605**

**Tel: 813-223-7673 - Fax: 813-248-0751 - [Carmanah@FirstChoiceMarineSupply.com](mailto:Carmanah@FirstChoiceMarineSupply.com)**

MODEL

# M708

SOLAR LED MARINE LANTERN

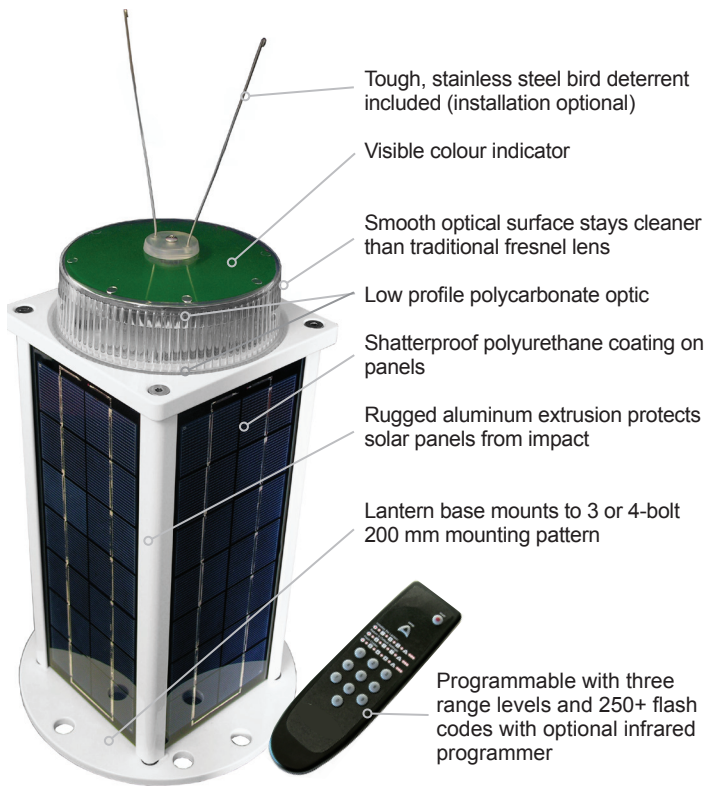

## EFFECTIVE INTENSITY

COLOUR	RANGE		
	LOW (3 NM)	MEDIUM (4 NM)	HIGH (5 NM)
Yellow	28.5 cd	66.4 cd	145.0 cd
Red	26.8 cd	63.8 cd	148.4 cd
Green	30.0 cd	70.0 cd	199.6 cd
White	30.5 cd	71.5 cd	268.5 cd

Note: Based on 0.3 second flash duration. Calculated using Schmidt Clausen Method. Effective Intensity Specifications for M708 RevB product.

## TECHNICAL FEATURES AND SPECIFICATIONS

<b>Solar Panel</b>	High-efficiency panels
<b>Battery</b>	Replaceable and recyclable best-in-class SLA battery pack with extreme temperature range.
<b>Light Source</b>	High power LEDs
<b>Peak Intensity (as per IALA rating)</b>	268.5 cd (white LEDs)
<b>Vertical Divergence</b>	> 7° (FWHM)
<b>Flash Patterns</b>	250+ (including steady-on)
<b>Construction</b>	Premium grade UV-resistant polycarbonate lens. Marine-grade powder-coated aluminum chassis with multiple Gore™ membrane vents.
<b>Colours</b>	Green, red, yellow, white. All colours fall within IALA Optimum (Dec. 2008) Chromaticity range.
<b>Operating Temperature</b>	-22 F to 122 F / -30 C to 50 C
<b>Storage Temperature</b>	-40 F to 176 F / -40 C to 80 C
<b>Weight</b>	26.2 lb / 11.88 kg
<b>Wind Loading</b>	140 knots / 260 km/h
<b>Ice Loading</b>	~10kg/m <sup>2</sup>
<b>Optional Automatic Light Control (ALC)</b>	When enabled, ALC will dynamically reduce brightness in response to unusually low amounts of sunlight to ensure continued operation.

## TECHNICAL DRAWINGS AND DIMENSIONS

### SIDE VIEW

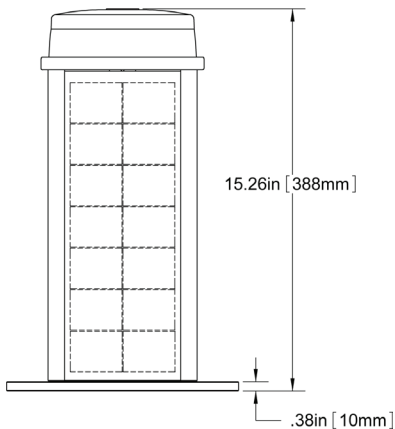

### TOP VIEW

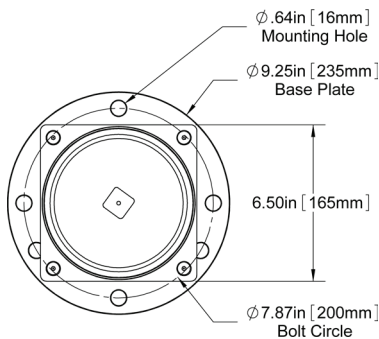

Specifications may be subject to change.

Carmanah is a Canadian public corporation - TSX:CMH  
 © 2010, Carmanah Technologies Corp.  
 Document: MARI\_M708\_SpecSheet\_RevC  
 US Patent Numbers 6,573,659, 7,572,030. Other patents pending.

The Carmanah Sabik logo is a joint trademark of Carmanah Technologies Corp. and Sabik Oy.

**First Choice Marine Supply - 120 N. 20th St. - Tampa, FL 33605**

**Tel: 813-223-7673 - Fax: 813-248-0751 - Carmanah@FirstChoiceMarineSupply.com**