



carmanah®  
we put solar to work



MODEL

# M650

SOLAR LED MARINE LANTERN

DESIGNED TO EXCEL IN THE WORLD'S MOST DEMANDING ENVIRONMENTS, THE M650 DELIVERS SOPHISTICATION, INTELLIGENCE AND PERFORMANCE THAT IS UNRIVALLED BY ANY OTHER LANTERN ON THE MARKET.

- **Unprecedented Reliability:** microprocessor Energy Management System (EMS) monitors and adapts the brightness to environmental conditions for consistent operation and long life under the toughest conditions.

- **Designed and tested to toughest industrial standards:**

**Immersion:** EN 60529: IP68; MIL-STD-202G: Method 104A, Test Condition B.

**Shock and Vibration:** MIL-STD-202G: Shock, Specified Pulse, Method 213B, Test Condition G; Vibration, Method 204, Test Condition B, 10g peak.

**Corrosion:** MIL-STD-810G: Salt Fog, Method 509.4, 2 cycles of 48 hr. at 35°C, ASTM B117-73 (1979).

**Solar Radiation:** MIL-STD-810G: Solar Radiation, Method 505.5, Procedure II, Climate cycle A2.

**Chemical Resistance:** Tested to MIL-STD-810G, Method 504, Procedure II.

**Hail:** EN 61215, 25mm OD up to 23m/s.

**EMC/EMI/ESD:** 47 CFR Part 15, Subpart B, Section 15.109; EN 60945: 2002, Clauses 9.1, 9.3, 10.1, 10.4 and 10.9; EN 61000: ESD, 6-2: 2005, table 1; 4-2: 200, 4-5: 2001, EMI, 4-3: 1995.

**Light Source:** IALA E-200-1 (2008); L70 lumen maintenance.

- **Self-contained and low maintenance:** all components are incorporated within a compact, user-friendly unit. The M650 also features a replaceable battery pack that extends the service life beyond five years, reducing the total cost of ownership and resulting in significant cost savings.

- **Intelligent settings:** the first solar product to incorporate intelligent deployment location settings that allow the M650 to be tuned to its location, protecting it against improper configuration. Lantern calculates peak intensity using Schmidt-Clausen for a user-selected effective intensity.

- Up to 44 cd IALA peak intensity and 4 NM visibility
- Available in all IALA Optimum chromaticities (Dec 2008)
- Intelligent deployment location settings protect against improper configuration
- Intuitive on-board user interface, infrared remote and software programmability
- Replaceable and recyclable battery pack

The M650 is the world's most advanced self-contained, high-performance, low-maintenance and easy-to-install solar LED marine lantern. Applications include: marine aids-to-navigation marking, marina and dock lighting, port lighting and hazard marking.

## TECHNICAL FEATURES AND SPECIFICATIONS

Solar Panel	High-efficiency cells with bypass and blocking diode function. Maximum power point tracking (MPPT) for optimal energy collection.
Battery	Tool-less replaceable and recyclable best-in-class battery pack with extreme temperature range. Battery status feedback of Good, Charge or Bad (Replace).
Light Source	High power LED. Colour-specific temperature corrected LED drivers provide consistent intensity under all operating conditions.
Peak Intensity (as per IALA rating)	44 cd (Green LEDs)
Vertical Divergence	> 8° (FWHM)
Flash Patterns	256+ (including steady-on)
Day / Night Transition	Selectable from 25 to 925 lux in 25 lux increments.
Construction	Premium grade UV resistant, polycarbonate/ polysiloxane co-polymer body and lens material. Double O-ring sealing with waterproof vent.
Colours	Green, Red, Yellow, Blue and White. As per IALA Recommendation E-200-1, dated December 2008.
Operating Temperature	-45 to 124 °F (-43 to 51 °C) ambient temperature The M650 will function up to 190 °F (88 °C) internal and surface temperatures.
Storage Temperature	-45 to 176 °F (-43 to 80 °C)
Color Indicator	Yes. Green, Red, Yellow, Blue or White
Weight	3.5 lb (1.58 kg)
Wind Loading	140 knots (72 m/s)
Ice Loading	22kg/m <sup>2</sup>
Automatic Light Control (ALC)	When enabled, ALC will dynamically reduce brightness in response to unusually low amounts of sunlight to ensure continued operation.



REPRESENTED BY:

MODEL

# M650

SOLAR LED MARINE LANTERN



## TECHNICAL DRAWINGS AND DIMENSIONS

SIDE VIEW

SWITCHED VIEW

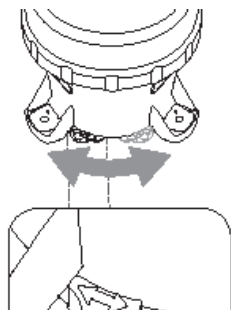
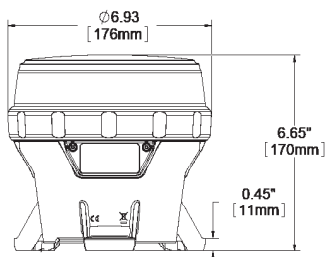

BC

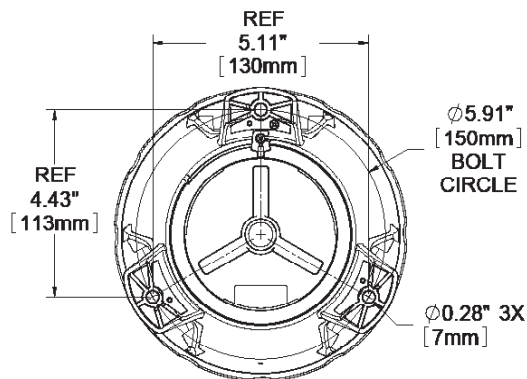

## PROGRAMMING AND CONFIGURATION OPTIONS

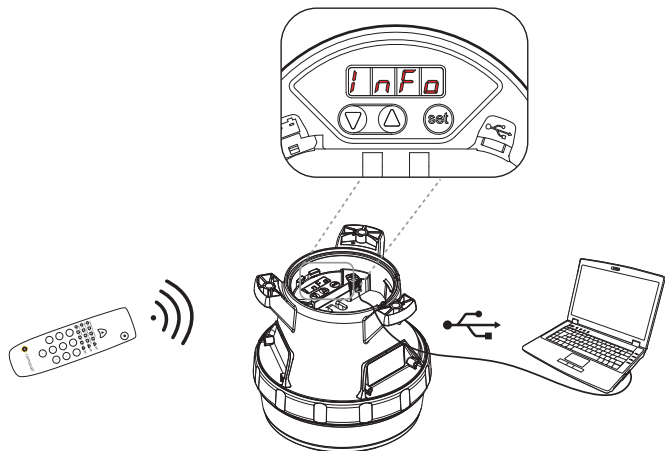

## PHOTOMETRIC PERFORMANCE

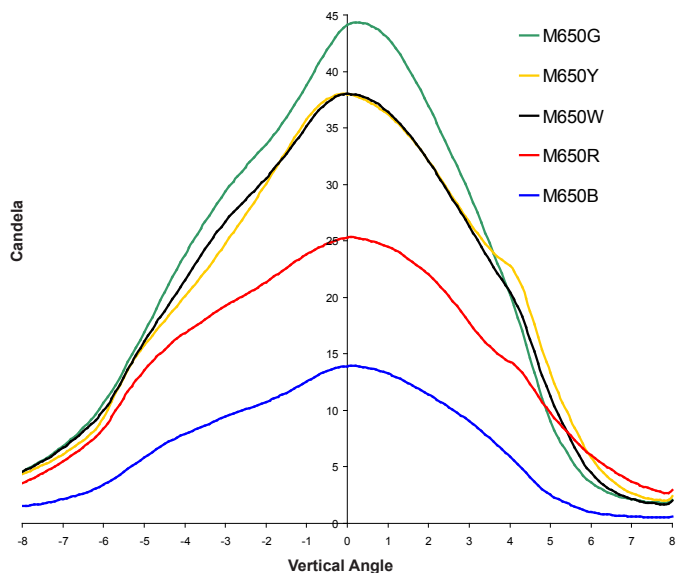

Note: Peak IALA intensity dependant on location. Plot based on equatorial location of 12-hour night duration and 21% duty cycle flash code.

## ORDERING CODES

LANTERNS	UNSWITCHED	SWITCHED
	M650 Green	M650G-0000
M650 Red	M650R-0000	M650R-0001
M650 Yellow	M650Y-0000	M650Y-0001
M650 Blue	M650B-0000	M650B-0001
M650 White	M650W-0000	M650W-0001

ACCESSORIES	
650 Bird Deterrent - Additional (1 ships with each lantern)	57003
650 Bottom Cover Replacement Kit	57392 (With Switch) 57393 (Without Switch)
650 Battery Replacement Pack	57383
650 Battery Charger	59648 (110V) 59188 (220V)
650 USB Cable	57394
650 Device Manager Software CD	61125
IR (Infrared) Programmer	56818

For a complete list of marine lantern accessories, please refer to the Carmanah Marine Lantern Accessories Sheet available on [carmanah.com](http://carmanah.com).

Specifications may be subject to change

Carmanah is a Canadian public corporation - TSX:CMH  
© 2010, Carmanah Technologies Corp.  
Document: M650\_SpecSheet\_RevC

US Patent No 6,573,659, Other patents pending. "Carmanah" and Carmanah logo are trademarks of Carmanah Technologies Corp.